

Tes-Pressure Kg.Sq.Cms	Hydraulic Seat-06 Body-10	Design Reference	ASME/ANSI-B16.5-1988 Ed
Tes-Pressure Kg.Sq.Cms	Pneumatic Seat-- Body--	Testing Reference	API-598-7Th.Ed
		NDT -	Not-Applicable
		Ends	Flange-Your Standards

-Dimensions l & D are to be provide by the client

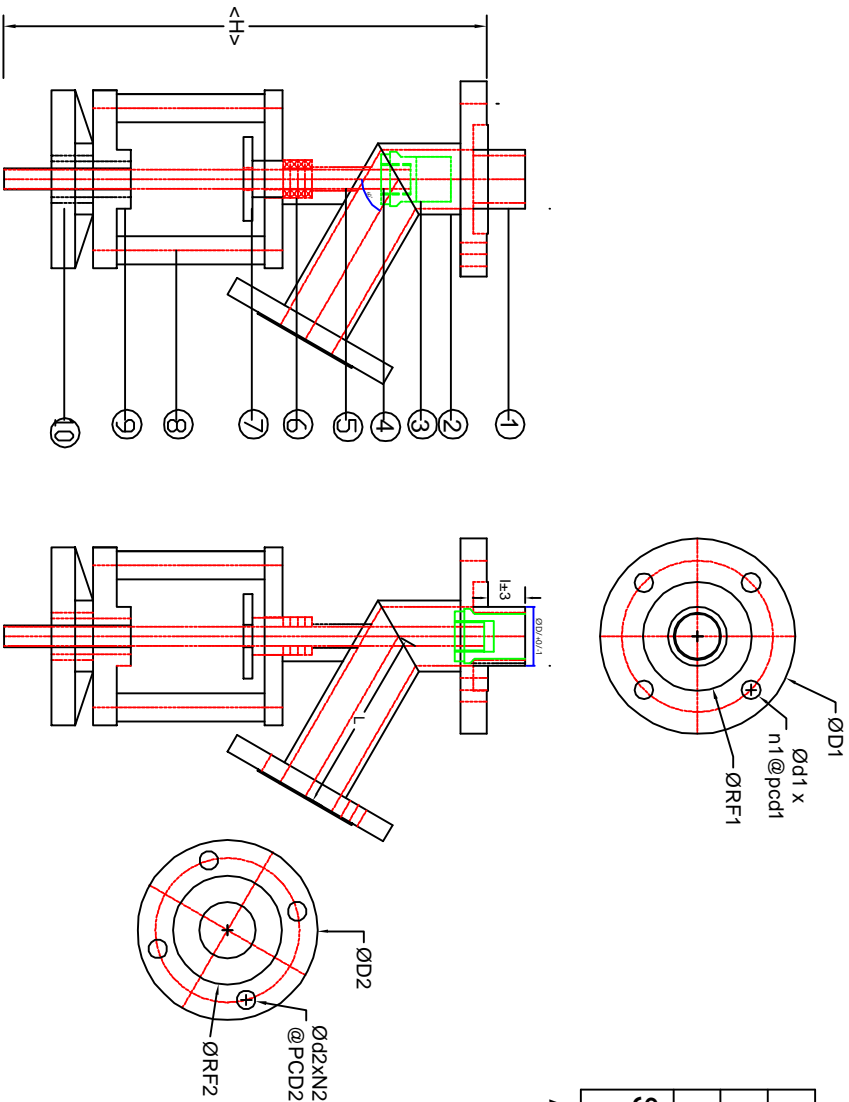

OPEN

CLOSE

100	260	195			215	180	
80	225	155			195	160	
50	180	105			160	125	
Size-mm NB	ØD1	ØRF1	Ød1 x n1 @ pcd1	ØD2	ØRF2	Ød2 x n2 @ pcd2	

FLANGES DIMENSIONS

Size-mm NB	L	H	I	ØD	Wt-Kg	Qty. No
100	225	475	40	110	50	2
80	195	450	40	90	38	5
50	165	425	40	63	26	3

ALL DIMENSSION ARE IN MM

SNo	DESCRIPTION	MOC	Rema
10	HAND-WHEEL	Malleable	
09	YOKE-BUSH	Malleable	
08	PILLARS	MS	
07	GLAND-BUSH	AISI-316	
06	GLAND-PACKINGS	Graphite	
05	SPINDLE	AISI-316	
04	DISC-NUT	ASTM A-351 Gr.CF3M	
03	DISC	ASTM A-351 Gr.CF3M	
02	BODY	ASTM A-351 Gr.CF3M	
01	SEAT BARREL	ASTM A-351 Gr.CF3M	

NAME	DATE	CLIENT		
DRN	28-11-10	M/s.Khatam Petro Novino Co		
DGN	PM	Iran		
CHD	PM	Client's PO No: MAIL/20/11/2023		
APPR	28-11-10	Client's Item No.		
SCALE		Model-Code-FBTM-2121-A		
DocNo.		Drawing No.-FBTM-2111		
TITLE:		FLUSH BOTTOM VALVE-INSIDE VALVE OPENING -FABRICATED		
NO	DATE	MATTER	BY	REVISION STATUS
1.				
2.				
3.				
4.				